

## THE FINITE BENDING OF CURVED PIPES

J. T. BOYLE

Department of Mechanics of Materials, University of Strathclyde, Glasgow, Scotland

(Received 15 October 1979; in revised form 30 June 1980)

**Abstract**—Using a thin shell theory developed by Reissner, a nonlinear model for the in-plane bending of a curved pipe is described. It is shown how classical thin shell models of this component can be deduced on making certain simplifying assumptions concerning the mode of deformation. By way of a numerical nonlinear analysis the problem of Brazier buckling of the curved pipe in pure bending is examined and compared to previous simplified solutions.

### 1. INTRODUCTION

Historically Theodore von Karman produced the earliest mathematical model of the bending of a curved pipe and many investigators have attempted to improve this analysis ever since. A full survey would of necessity repeat most of the extensive reviews which have appeared in the literature (e.g. Refs. [1, 2]) and shall therefore not be duplicated here in any depth. Instead the treatment of the in-plane bending of a curved pipe as a problem in the theory of thin shells shall be examined.

By a suitable modification of the equations for a shell of revolution Reissner [3] developed a general model of the in-plane bending of a thin, elastic arbitrary cross section smooth curved pipe which contained all the characteristics of the von Karman theory, although particular equations for a cross section composed of circular arcs had earlier been established by Tueda [4]. Minor inconsistencies in these analyses were later removed by Reissner and Wan [5]. All of these studies are primarily concerned with the small deformation problem and, as far as the author is aware, only the publications of Crandall and Dahl [6], Reissner [7], Kostovetski [8], Robert and Duforet [9] and Sobel and Newman [10] deal briefly with the finite deflection situation.

It is the purpose here to re-examine the von Karman–Reissner theory from a more general standpoint by developing a nonlinear deformation thin shell model of a curved pipe. It is also shown how the classical equations [6]—and consequently also the linear models [3, 5]—can be deduced on making certain simplifying assumptions. The final form of this theory has been used to examine the behaviour of a pressurised curved pipe [11, 12]. Here the Brazier buckling of the curved pipe in pure bending is examined and compared to the existing simplified solutions.

### 2. DIFFERENTIAL GEOMETRY OF A CURVED PIPE

A smooth curved pipe can be recognised as a thin shell whose midsurface is geometrically equivalent to that sector of a torus formed by rotating a closed curve  $C$ , with parametric equations  $r(\xi)$  and  $l(\xi)$  about an axis in the direction  $k$ , normal to the plane of the bend, through an angle  $\Theta$ . It may therefore be described by the triad  $(t_\xi, t_\theta, n)$  of midsurface unit tangent vectors  $t_\xi$ ,  $t_\theta$  and normal vector  $n = t_\xi \times t_\theta$  and the associated orthogonal coordinate system  $(\xi, \theta, \zeta)$  where  $\theta$  is the circumferential angle:  $-\Theta/2 \leq \theta \leq \Theta/2$  and  $\zeta$  is measured normal to the midsurface,  $-h/2 \leq \zeta \leq h/2$ , (Fig. 1).

The curvatures of this surface are given by the Gauss–Weingarten relations [13]

$$\begin{aligned} \frac{1}{\alpha} t'_\xi &= \frac{1}{s_\xi} t_\theta - \frac{1}{r_\xi} n & \frac{1}{r} t'_\xi &= \frac{1}{s_\theta} t_\theta - \frac{1}{r_{\theta\xi}} n \\ \frac{1}{\alpha} t'_\theta &= -\frac{1}{s_\xi} t_\xi - \frac{1}{r_{\xi\theta}} n & \frac{1}{r} t'_\theta &= -\frac{1}{s_\theta} t_\xi - \frac{1}{r_\theta} n \end{aligned} \quad (1)$$

where

$$(\cdot)' = \frac{\partial(\cdot)}{\partial \xi} \quad (\cdot)' = \frac{\partial(\cdot)}{\partial \theta}$$

By suitable manipulation it can be shown that the in-plane curvatures are

$$\frac{1}{s_\xi} = 0 \quad \frac{1}{s_\theta} = \frac{\cos \phi}{r}$$

while the out of plane curvatures are

$$\frac{1}{r_\xi} = -\frac{\phi'}{\alpha} \quad \frac{1}{r_{\theta\xi}} = \frac{1}{r_{\xi\theta}} = 0 \quad \frac{1}{r_\theta} = -\frac{\sin \phi}{r}$$

where  $\phi$  is the tangent angle to the meridional curve  $C$  (Fig. 1) and

$$r' = \alpha \cos \phi \quad l' = \alpha \sin \phi.$$

### 3. DEFORMATION OF A CURVED PIPE

A major problem which arises in the construction of a suitable finite displacement model of a thin shell is the determination of the "best" means of describing the deformed mid surface. To this end the following fundamental assumption concerning the mode of deformation of a curved pipe under in-plane bending is made.

#### Assumption 1

The deformed midsurface can be achieved from the undeformed midsurface by a rotation  $\beta$  about  $t_\theta$  followed by a rotation  $\omega$  about  $k$ .

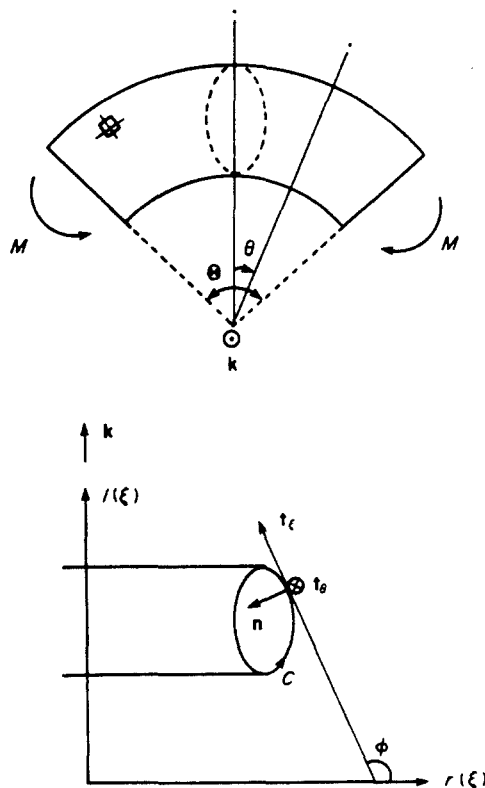

Fig. 1. Geometry of a curved pipe.

The former rotation is within the meridional plane while the latter is purely in the plane of the bend (Fig. 2). Furthermore the deformation as described is admissible since these rotations are commutative. The triad  $(t_\xi, t_\theta, n)$  is transformed into the triad  $(T_\xi, T_\theta, N)$  under this assumption and it is readily shown that these are related by

$$\begin{bmatrix} T_\xi \\ T_\theta \\ N \end{bmatrix} = \begin{bmatrix} \cos \omega + (1 - \cos \omega) \sin^2 \Phi & \sin \omega \cos \Phi & (1 - \cos \omega) \cos \Phi \sin \Phi \\ -\sin \omega \cos \Phi & \cos \omega & \sin \Phi \sin \omega \\ (1 - \cos \omega) \cos \Phi \sin \Phi & -\sin \omega \sin \Phi & \cos \omega + (1 - \cos \omega) \cos^2 \Phi \end{bmatrix} \begin{bmatrix} t_\xi \\ t_\theta \\ n \end{bmatrix}$$

where  $\Phi = \phi - \beta$ .

In the following expressions for the derivatives of the vectors  $(T_\xi, T_\theta, N)$  shall be required: analogous to the Gauss-Weingarten relations (1) these can be shown to be

$$\begin{aligned} \frac{T'_\xi}{\alpha} &= \frac{1}{S_\xi} T_\theta - \frac{1}{R_\xi} N & \frac{T'_\xi}{r} &= \frac{1}{S_\theta} T_\theta - \frac{1}{R_{\theta\xi}} N \\ \frac{T'_\theta}{\alpha} &= -\frac{1}{S_\xi} T_\xi - \frac{1}{R_{\theta\theta}} N & \frac{T'_\theta}{r} &= -\frac{1}{S_\theta} T_\xi - \frac{1}{R_\theta} N \end{aligned} \tag{2}$$

where

$$\begin{aligned} \frac{1}{S_\xi} &= \frac{\cos \Phi}{\alpha} \omega', & \frac{1}{S_\theta} \left[ \frac{1}{3} \right] &= \frac{\cos \Phi}{r} (1 + \omega') \\ \frac{1}{R_\xi} &= -\frac{\Phi'}{\alpha} & \frac{1}{R_{\theta\xi}} &= -\frac{\sin \Phi}{\alpha} \omega', & \frac{1}{R_{\theta\xi}} &= \frac{\beta'}{r} & \frac{1}{R_\theta} &= -\frac{\sin \Phi}{r} (1 + \omega'). \end{aligned}$$

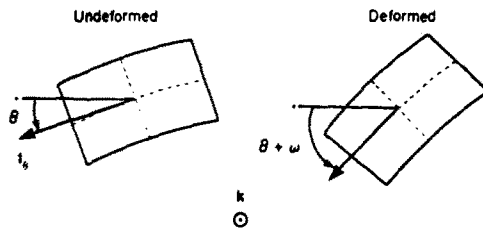

(a) Circumferential deformation of an element of the midsurface

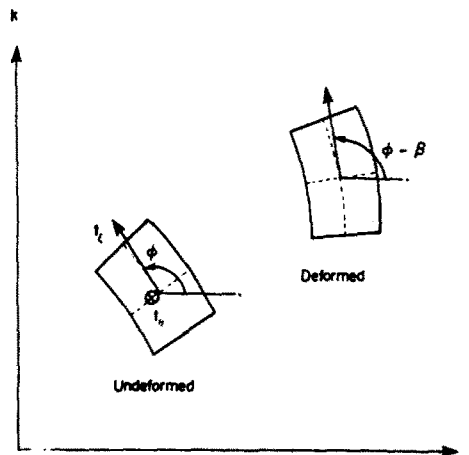

(b) Meridional deformation of an element of the cross section

Fig. 2. Deformation of a curved pipe.

## 4. A NONLINEAR THIN SHELL MODEL OF A CURVED PIPE

Nonlinear thin shell theory has reached a fair degree of sophistication (see, e.g. Ref. [14]), yet in practice it is still very much in its infancy. Perhaps the most functional theory was advanced by Reissner in a series of publications [15, 16]. The principle of this theory, which was only applicable to shells of revolution, was that the deformed midsurface could best be described from the undeformed midsurface by a single, finite rotation. This idea was perfected for arbitrary shell geometries by Simmonds and Danielson [17] but was still only valid for a single rotation. This restriction was later removed in an important paper by Reissner [18]. It is this general theory of Reissner's which shall be used here.

The deformed midsurface of the curved pipe can be described either by its tangential and normal vectors or by the triad  $(\mathbf{T}_\xi, \mathbf{T}_\theta, \mathbf{N})$ . In Reissner's theory the difference between these is used as a measure of the state of strain. Thus if  $\rho(\xi, \theta)$  is the equation of the deformed midsurface (with  $r(\xi, \theta)$  the equation of the undeformed midsurface) then the in-plane strain resultants  $\epsilon_\xi$ ,  $\epsilon_{\xi\theta}$ ,  $\epsilon_{\theta\xi}$  and  $\epsilon_\theta$  and the transverse (shearing strain resultants)  $\gamma_\xi$  and  $\gamma_\theta$  are defined through the differentiation formulae

$$\begin{bmatrix} \rho' \\ \alpha \\ \rho' \\ r \end{bmatrix} = \begin{bmatrix} (1 + \epsilon_\xi) & \epsilon_{\xi\theta} & \gamma_\xi \\ \epsilon_{\theta\xi} & (1 + \epsilon_\theta) & \gamma_\theta \end{bmatrix} \begin{bmatrix} \mathbf{T}_\xi \\ \mathbf{T}_\theta \\ \mathbf{N} \end{bmatrix}.$$

If the displacement vector  $\mathbf{u}$  is defined by

$$\mathbf{u} = \rho - r$$

and if scalar displacements  $u_\xi$ ,  $u_\theta$  and  $w$  given by

$$\mathbf{u} = u_\xi \mathbf{t}_\xi + u_\theta \mathbf{t}_\theta + w \mathbf{n}$$

are introduced, and if we further define

$$\begin{aligned} u_1 &= (u + r) \sin \omega - u_\theta \cos \omega & u &= u_\xi \cos \phi - w \sin \phi \\ u_2 &= (u + r) \cos \omega + u_\theta \sin \omega \\ v_1 &= v + l & v &= u_\xi \sin \phi + w \cos \phi \\ \Phi &= \phi - \beta & W &= \theta + \omega \end{aligned}$$

then the strain displacement relations can be written in the simple form

$$\begin{aligned} \epsilon_\xi &= \frac{\cos \Phi}{\alpha} (u_2' + u_1 W') + \frac{\sin \Phi}{\alpha} v_1' - 1 \\ \epsilon_{\xi\theta} &= -\frac{1}{\alpha} (u_1' - u_2 W') \\ \epsilon_{\theta\xi} &= \frac{\cos \Phi}{r} (u_2' + u_1 W') + \frac{\sin \Phi}{r} v_1' \\ \epsilon_\theta &= -\frac{1}{r} (u_1' - u_2 W') - 1 \\ \gamma_\xi &= -\frac{\sin \Phi}{\alpha} (u_2' + u_1 W') + \frac{\cos \Phi}{\alpha} v_1' \\ \gamma_\theta &= -\frac{\sin \Phi}{r} (u_2' + u_1 W') + \frac{\cos \Phi}{r} v_1' \end{aligned}$$

The transverse (bending and twisting) strain couples  $\kappa_\xi$ ,  $\kappa_{\xi\theta}$ ,  $\kappa_{\theta\xi}$  and  $\kappa_\theta$  and the in-plane strain

couples  $\lambda_\xi$  and  $\lambda_\theta$  are defined by the difference between the deformed and undeformed curvatures in the differentiation formulae (1) and (2)

$$\begin{aligned} \kappa_\xi &= -\frac{\Phi'}{\alpha} - \frac{1}{r_\xi} \\ \kappa_{\xi\theta} &= -\frac{\sin \Phi}{\alpha} W' \\ \kappa_{\theta\xi} &= -\frac{\Phi'}{r} \\ \kappa_\theta &= \frac{\sin \phi}{r} - \frac{\sin \Phi}{r} W' \\ \lambda_\xi &= \frac{\cos \Phi}{\alpha} W' \\ \lambda_\theta &= \frac{\cos \Phi}{r} W' - \frac{\cos \phi}{r}. \end{aligned} \tag{4}$$

The relations (3) and (4) represent the basic strain displacement relations for the in-plane deformation of a thin curved pipe. The equations of equilibrium are easily found from balance of forces and moments

$$\begin{aligned} (\alpha N_\xi)' + (r N_\theta)' + \alpha r p &= 0 \\ (r M_\xi)' + (\alpha M_\theta)' + \rho' \times (r N_\xi) + \rho \times (\alpha N_\theta) + \alpha r q &= 0 \end{aligned} \tag{5}$$

where  $N_\xi$  and  $N_\theta$  and  $M_\xi$  and  $M_\theta$  and forces and moments per unit undeformed length and  $p$  and  $q$  are applied forces and moments per unit undeformed area. These reduce to six scalar equilibrium equations on defining

$$\begin{aligned} \begin{bmatrix} N_\xi \\ N_\theta \\ p \end{bmatrix} &= \begin{bmatrix} N_\xi & N_{\xi\theta} & Q_\xi \\ N_{\theta\xi} & N_\theta & Q_\theta \\ p_\xi & p_\theta & p_N \end{bmatrix} \begin{bmatrix} T_\xi \\ T_\theta \\ N \end{bmatrix} \\ \begin{bmatrix} M_\xi \\ M_\theta \\ q \end{bmatrix} &= \begin{bmatrix} M_\xi & M_{\xi\theta} & P_\xi \\ M_{\theta\xi} & M_\theta & P_\theta \\ q_\xi & q_\theta & q_N \end{bmatrix} \begin{bmatrix} N \times T_\xi \\ N \times T_\theta \\ N \end{bmatrix}. \end{aligned}$$

A more conventional shell theory [16, 18] is obtained on setting

$$P_\xi = P_\theta = 0 \quad \gamma_\xi = \gamma_\theta = 0.$$

### 5. THE PURE BENDING PROBLEM

The preceding formulation should be sufficient as a general model of the kinetics and statics of a smooth curved pipe under the action of in-plane bending. Classical (small deformation) forms of the equations are primarily concerned with the so-called "pure bending" problem [5]. Essentially this assumes that the pipe remains approximately in the form of a smooth circular arc during deformation, or, alternatively, that plane meridional sections remain plane. The following assumption seems consistent with the adoption of pure bending [5]

#### Assumption 2

Bending is uniform and the strains remain rotationally symmetric, with shear strains vanishing.

A suitable displacement field which satisfies this condition is seen to be, from examination of (3) and (4),

$$\begin{aligned} u_1 &= 0 \\ u_2 &= u_2(\xi) \\ v &= v_1(\xi) \\ \Phi &= \Phi(\xi) \\ W &= K\theta + K_0 \end{aligned} \tag{6}$$

and, without loss in generality, we may take  $K_0 = 0$  in the following. These conditions are satisfied if, and only if,

$$\cos \omega \approx 1$$

that is, if  $\omega$  is small and by implication

$$\sin \omega \approx \omega \quad u_2 = u + r.$$

Then

$$u_\theta = \omega(u + r) \tag{7}$$

with

$$\omega = k\theta \tag{8}$$

where the constant  $k$  can be identified as the fractional change in angle of the bend

$$k = \frac{\delta\Theta}{\Theta} \quad K = k + 1.$$

The strain displacement relations (3) then become

$$\begin{aligned} \epsilon_\xi &= \frac{\cos \Phi}{\alpha} u'_2 + \frac{\sin \Phi}{\alpha} v'_1 - 1 \\ \epsilon_\theta &= \frac{1}{r} u_2 K - 1 \\ \gamma_\xi &= -\frac{\sin \Phi}{\alpha} u'_2 + \frac{\cos \Phi}{\alpha} v'_1 \\ \gamma_\theta &= 0 \\ \kappa_\xi &= -\frac{\Phi'}{\alpha} - \frac{1}{r_\xi} \\ \kappa_\theta &= \frac{\sin \phi}{r} - \frac{\sin \Phi}{r} K \\ \lambda_\xi &= 0 \\ \lambda_\theta &= \frac{\cos \Phi}{r} K - \frac{\cos \phi}{r} \end{aligned} \tag{9}$$

while the equilibrium equations are

$$\frac{(rN_\xi)'}{\alpha r} + \left( \kappa_\xi + \frac{1}{r_\xi} \right) Q - \lambda_\theta N_\theta + p_\xi = 0$$

$$\begin{aligned} \frac{(rQ)'}{\alpha r} - \left( N_\xi \left( \kappa_\xi + \frac{1}{r_\xi} \right) + N_\theta \left( \kappa_\theta + \frac{1}{r_\theta} \right) \right) + p_N &= 0 \\ \frac{(rM_\xi)' - r'M_\theta}{\alpha r} - (1 + \epsilon_\xi)Q - \lambda_\theta M_\theta + q_\xi &= 0 \\ p_\xi = 0 \quad p_N = -p \quad q_\xi = 0 \end{aligned} \tag{10}$$

with elastic constitutive relations

$$\begin{aligned} N_\xi &= C(\epsilon_\xi + \nu\epsilon_\theta) \quad M_\xi = D(\kappa_\xi + \nu\kappa_\theta) \\ N_\theta &= C(\epsilon_\theta + \nu\epsilon_\xi) \quad M_\theta = D(\kappa_\theta + \nu\kappa_\xi) \end{aligned} \tag{11}$$

or

$$\begin{aligned} \epsilon_\xi &= B(N_\xi - \nu N_\theta) \quad \kappa_\xi = A(M_\xi - \nu M_\theta) \\ \epsilon_\theta &= B(N_\theta - \nu N_\xi) \quad \kappa_\theta = A(M_\theta - \nu M_\xi) \end{aligned} \tag{12}$$

where

$$A = \frac{12}{Eh^3} \quad B = \frac{1}{Eh} \quad C = \frac{Eh}{1-\nu^2} \quad D = \frac{Eh^3}{12(1-\nu^2)}$$

Further, equilibrium with an external moment  $M$  is satisfied with

$$M = \oint (u_2 N_\theta - M_\theta \sin \Phi) \alpha \, d\xi \tag{13}$$

where  $a$  is the mid-line radius of the bend.

The form of (9) is reducible to that used by Crandall and Dahl[6] except for the term  $(ku/r)$  in  $\epsilon_\theta$  and  $(-\sin \phi/r) k$  in  $\kappa_\theta$  which are not expected to be significant. Also the identity (7) between  $u_\theta$  and  $\omega$  is similar to that used by Reissner[7],

$$u_\theta = k\theta(r - a + u)$$

but this does not ensure vanishing of shear strains. However equations reduce to known linear equations[5] for pure bending assuming small deformations.

### 6. ANALYSIS OF PURE BENDING

In order to numerically resolve the problem we write the equations in the following form as first order ordinary differential equations

$$\begin{aligned} \frac{\Phi'}{\alpha} &= - \left( \kappa_\xi + \frac{1}{r_\xi} \right) \\ (rN_\xi)' &= r'N_\theta - \alpha r \left( \kappa_\xi + \frac{1}{r_\xi} \right) Q + \alpha r \lambda_\theta N_\theta - \alpha r p_\xi \\ (rQ)' &= \alpha r \left( N_\xi \left( \kappa_\xi + \frac{1}{r_\xi} \right) + N_\theta \left( \kappa_\theta + \frac{1}{r_\theta} \right) \right) - \alpha r p_N \\ (rM_\xi)' &= r'M_\theta + \alpha r(1 + \epsilon_\xi)Q + \alpha r \lambda_\theta M_\theta - \alpha r q_\xi \\ u_2' &= \alpha(1 + \epsilon_\xi) \cos \Phi - \alpha \gamma_\xi \sin \Phi \\ v_1' &= \alpha(1 + \epsilon_\xi) \sin \Phi + \alpha \gamma_\xi \cos \Phi \end{aligned} \tag{14}$$

where

$$\gamma_\xi = 0$$

$$\lambda_\theta = \frac{\cos \Phi}{r} K - \frac{\cos \phi}{r}$$

$$\kappa_\xi = \frac{M_\xi}{D} - \nu \kappa_\theta$$

$$\epsilon_\xi = \frac{N_\xi}{C} - \nu \epsilon_\theta$$

$$N_\theta = \frac{\epsilon_\theta}{B} + \nu N_\xi$$

$$M_\theta = \frac{\kappa_\theta}{A} + \nu M_\xi$$

$$\kappa_\theta = \frac{\sin \phi}{r} - \frac{\sin \Phi}{r} K$$

$$\epsilon_\theta = \frac{u_2}{r} K - 1. \quad (15)$$

These constitute a system of six first order differential equations in the unknowns  $N_\xi$ ,  $Q$ ,  $M_\xi$ ,  $u_2$ ,  $v_1$  and  $\Phi$ . There is also the subsidiary unknown  $K$  which can either be specified, with the resultant moment calculated according to (13), or assumed unknown with

$$K' = 0 \quad (16)$$

with (13) used as an end condition. The form used is similar to that used by Kalnins[19] and Robert and Duforet[10] and differs from that used in the previous papers by the author[11, 12] which were second order equations based on the so-called "bending equations"[5].

For a circular cross section, Fig. 3,

$$r = a + b \sin \xi \quad l = -b \cos \xi \quad \alpha = b \quad \phi = \xi$$

and bearing in mind the boundary conditions implied by symmetry

$$\beta = 0 \quad Q = 0 \quad v = 0, \quad \xi = \frac{\pi}{2} \quad \frac{3\pi}{2} \quad (17)$$

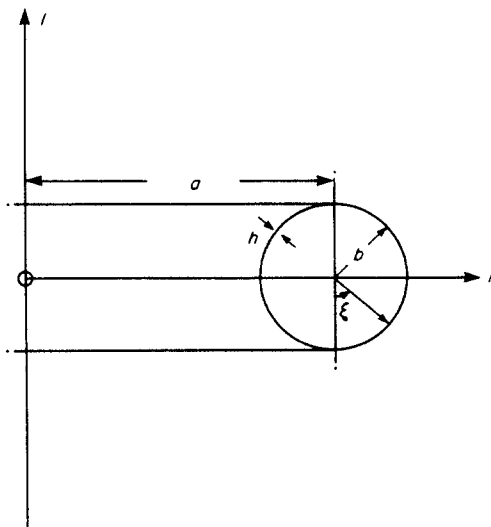

Fig. 3. Circular cross section.



if normalised variables are defined by

$$Y_1 = \Phi \quad Y_2 = \frac{v_1}{b} \quad Y_3 = \frac{rQ}{bh\sigma_0} \quad Y_4 = \frac{rM_\xi}{bh^2\sigma_0} \quad Y_5 = \frac{rN_\xi}{bh\sigma_0} \quad Y_6 = \frac{u_2}{b}$$

$$Z_1 = \alpha\kappa_\xi \quad Z_2 = \alpha\lambda_\theta \quad Z_3 = \frac{rN_\theta}{bh\sigma_0} \quad Z_4 = \frac{rM_\theta}{bh^2\sigma_0} \quad Z_5 = \epsilon_\xi \quad Z_6 = \alpha\kappa_\theta \quad Z_7 = \epsilon_\theta$$

then the basic equations become

$$Y_1' = -Z_1 + 1$$

$$Y_2' = (1 + Z_3) \sin Y_1$$

$$Y_3' = Y_5(Z_1 - 1) + Z_3 \left( Z_6 - \frac{c_8 \sin \xi}{1 + c_8 \sin \xi} \right) + (1 + c_8 \sin \xi) c_1 \frac{\rho}{E}$$

$$Y_4' = \left( \frac{c_8 \cos \xi}{1 + c_8 \sin \xi} + Z_2 \right) Z_4 + (1 + Z_3) c_2 Y_3$$

$$Y_5' = \left( \frac{c_8 \cos \xi}{1 + c_8 \sin \xi} + Z_2 \right) Z_3 + (1 - Z_1) Y_3$$

$$Y_6' = (1 + Z_3) \cos Y_1 \quad (18)$$

$$Z_1 = \frac{c_3 Y_4}{1 + c_8 \sin \xi} - \nu Z_6$$

$$Z_2 = \frac{c_8}{1 + c_8 \sin \xi} (\cos Y_1 \cdot K - \cos \xi)$$

$$Z_3 = (1 + c_8 \sin \xi) c_4 Z_7 + \nu Y_5$$

$$Z_4 = (1 + c_8 \sin \xi) c_5 Z_6 + \nu Y_4$$

$$Z_5 = \frac{c_6 Y_5}{1 + c_8 \sin \xi} - \nu Z_7$$

$$Z_6 = \frac{c_8}{1 + c_8 \sin \xi} (\sin \xi - \sin Y_1 \cdot K)$$

$$Z_7 = \frac{c_8 Y_6}{1 + c_8 \sin \xi} K - 1 \quad (19)$$

where

$$c_1 = \frac{Ea}{h\sigma_0} \quad c_2 = \frac{b}{h} \quad c_3 = \frac{b^2 h^2 \sigma_0}{aD} \quad c_4 = \frac{a}{bh\sigma_0 B}$$

$$c_5 = \frac{a}{b^2 h^2 \sigma_0 A} \quad c_6 = \frac{bh\sigma_0}{aC} \quad c_7 = \frac{h}{a} \quad c_8 = \frac{b}{a}$$

The boundary conditions become

$$Y_1 = \pi/2 \quad Y_2 = 0 \quad Y_3 = 0, \quad \xi = \pi/2$$

$$Y_1 = 3\pi/2 \quad Y_2 = 0 \quad Y_3 = 0, \quad \xi = 3\pi/2$$

and the equations may be integrated in the range  $\pi/2 \leq \xi \leq 3\pi/2$ .

Moment equilibrium is given as

$$\frac{M}{b^2 h \sigma_0} = 2 \int_{\pi/2}^{3\pi/2} \frac{1}{1 + c_8 \sin \xi} \left( (c_8 \sin \xi (1 + Z_7) + Z_7) \frac{Z_3}{K} - c_7 Z_4 \sin Y_1 \right) d\xi \quad (20)$$

and the stresses

$$\sigma_{\xi} = \frac{N_{\xi}}{h} + \zeta \frac{12}{h^2} M_{\xi}$$

$$-1/2 \leq \zeta \leq +1/2$$

$$\sigma_{\theta} = \frac{N_{\theta}}{h} + \zeta \frac{12}{h^2} M_{\theta}$$

can be obtained from

$$\frac{\sigma_{\xi}}{\sigma_0} = \frac{c_8}{1 + c_8 \sin \xi} (Y_5 + 12\zeta Y_4)$$

$$\frac{\sigma_{\theta}}{\sigma_0} = \frac{c_8}{1 + c_8 \sin \xi} (Z_3 + 12\zeta Z_4). \quad (21)$$

So far  $\sigma_0$  has been arbitrary, but on choosing  $\sigma_0 = Eh/b$  the coefficients  $c_i$  can be written in terms of the geometric parameters:  $\lambda = \text{pipe bend parameter} = ah/b^2$ ; and  $\rho = \text{radius ratio} = b/a$ , and on defining

$$\alpha = k \frac{\sqrt{[12(1-\nu^2)]}}{\lambda} \quad m = \frac{M}{\pi h^2 b} \frac{\sqrt{[12(1-\nu^2)]}}{E}$$

the normalised parameters obtained by Reissner[7] are regained. (For the straight pipe, using  $m$  and  $\alpha$  as defined, there is then no dependence on the ratio  $b/h$ ).

Normal pipe bend variables are given as

$$\text{IK} = \text{flexibility factor} = \frac{\alpha}{m}$$

$$\text{SCF} = \text{stress concentration factor} = \frac{\sigma}{\sigma_0} \frac{\sqrt{[12(1-\nu^2)]}}{m}.$$

The equations are now in a form suitable for numerical analysis. This shall be considered in the following.

#### 7. BRAZIER BUCKLING OF CURVED PIPES

For curved pipes with large radius, Reissner[7] obtained the following approximate relationship between  $m$  and  $\alpha$

$$m = \alpha \left( 1 - \frac{1}{16}(\mu + \alpha)(\mu + 2\alpha) \right) \quad (22)$$

where

$$\mu = \frac{\sqrt{[12(1-\nu^2)]}}{\lambda}$$

which is valid provided  $b \ll a$  and

$$\lambda \geq \frac{\sqrt{[12(1-\nu^2)]}}{2}.$$

According to the above result the value of  $m$  is largest when a critical value of  $\alpha$  given by

$$\alpha_c = 2 \sqrt{\left( \frac{2}{3} + \frac{\mu^2}{48} \right) - \frac{\mu}{2}} \quad (23)$$

is reached, which corresponds to a flattening instability known as "Brazier buckling" [7, 20]. The formula, eqn (22), reduces to the classical result due to Brazier [20] for the straight pipe in the limit as  $\lambda \rightarrow \infty$ . While there is a substantial literature on this phenomenon for the straight pipe [21], there is little information for the curved pipe.

In Reissner's analysis it is assumed that the material constant  $C = Eh$  rather than  $C = Eh/(1 - \nu^2)$  which is used here; if the latter is assumed then relation (22) takes the alternative form

$$m = \frac{\alpha}{1 - \nu^2} \left( 1 - \frac{1}{16} \frac{(\mu + \alpha)(\mu + 2\alpha)}{(1 - \nu^2)} \right). \tag{24}$$

A slightly different result, which has a greater range of validity was derived in Ref. [22] as

$$m = \frac{\alpha}{1 - \nu^2} \left( 1 - \frac{1}{16} \frac{(\mu + \alpha)(\mu + 2\alpha)}{(1 - \nu^2) + \frac{5}{72}(\mu + \alpha)^2} \right). \tag{25}$$

As far as the author is aware, the only other study relating to the problem of Brazier buckling in curved pipes is an incomplete analysis developed by Kostovetskii [8], which is briefly described here in an Appendix.

A FORTRAN computer program was written to numerically resolve the eqns (18) using quasilinearisation and multi-point shooting (see Ref [11]). Load-deflection diagrams for various  $\lambda$  and  $\rho$  bearing in mind the thin-shell condition

$$\frac{h}{b} = \lambda \rho \ll 1$$

are given in Fig. 4, together with the results of formulae (24) and (25) and Kostovetskii's analysis.

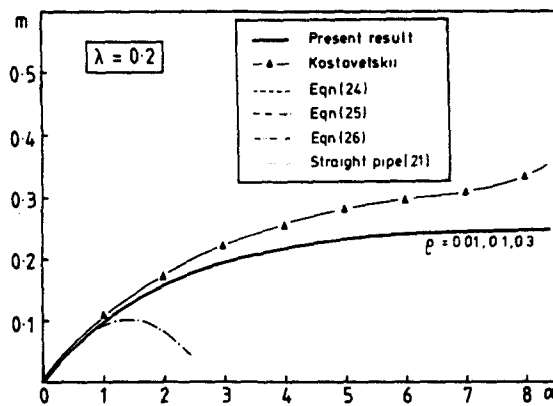

Fig 4-1

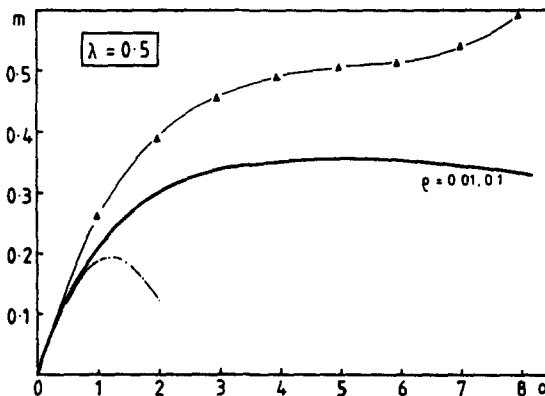

Fig 4-2

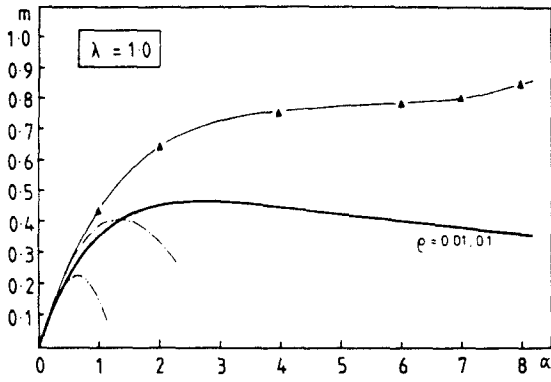

Fig 4-3

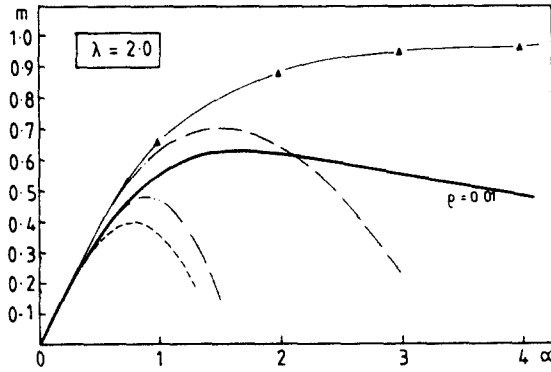

Fig 4-4

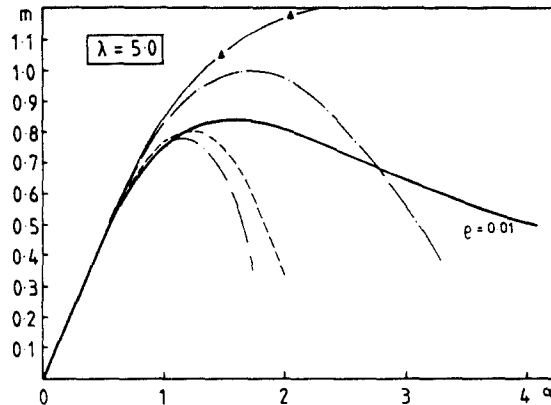

Fig 4-5

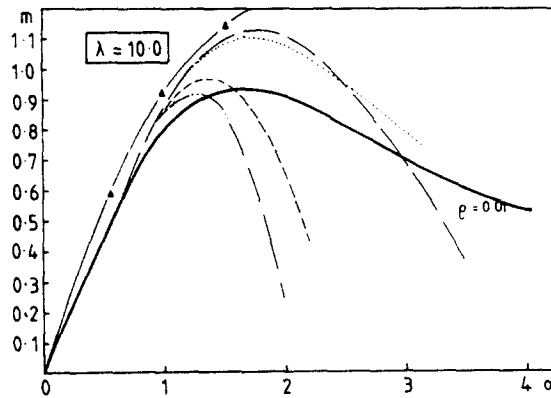

Fig 4-6

Fig. 4. Load deflection diagrams,  $m, \alpha$ .

It is immediately apparent that a critical (limit type) behaviour, similar to Brazier buckling in a straight pipe can also be obtained for some geometries of curved pipe. A critical bending moment, where it exists, increases with the pipe bend parameter  $\lambda$  and there is little dependence on the radius ratio  $\rho$ . The variation of critical bending moment,  $m_c$ , with the pipe bend parameter is shown in Fig. 5 together with results obtained from the simple analyses. It may be inferred from this that the critical bending moment tends to that obtained for the straight pipe; that this is indeed the case has been established by Reissner[23]. If the variation in corresponding critical curvature,  $\alpha_c$ , with pipe bend parameter is also deduced, Fig. 6, then it can be seen that in the limit the critical curvature for a curved pipe also tends to that of a straight pipe. The computed results obtained here suggest that the critical curvature rapidly increases with decreasing  $\lambda$  in the range  $\lambda < 1.5$ . This behaviour is substantially different from that predicted by the simple analyses, eqns (24) and (25) which indicate a decreasing critical curvature with pipe bend parameter; because of this the load-deflection diagrams for the simple analyses take a different form from that obtained here, Fig. 4. Examination of Fig. 5 shows that the critical moment calculated here is virtually identical to that calculated from eqn (24) for values of  $\lambda > 5$ , while that obtained from eqn (25) is better in the range  $1 < \lambda < 2$ .

It can also be seen from Fig 4 that the results of Kostovetskii's analysis are considerably higher than the other analyses. Indeed in the limit as  $\lambda \rightarrow \infty$  Kostovetskii's results for the straight pipe are close to those of Chwalla[24] which are much higher than those of Brazier. This discrepancy for the straight pipe is often attributed [7, 21] to Chwalla's presumption that the deformed cross-section is truly elliptical rather than oval; however, this is not assumed in Kostovetskii's analysis. An interesting observation made by Spence and Toh[21] is that if certain small order terms neglected in Brazier's analysis, but present in Chwalla's and Kostovetskii's are retained then the critical moment is increased. If these higher order terms are omitted from Kostovetskii's analysis, then the following result is obtained

$$m = \frac{\alpha}{1-\nu^2} \left( 1 - \frac{1}{16} \frac{(\mu + \alpha)(\mu + 2\alpha)}{(1-\nu^2) + \frac{5}{72}((\mu + \alpha)^2 - \frac{9}{5}\alpha(\alpha + \mu))} \right) \quad (26)$$

which is also shown in Figs. 4-6 and can be compared with eqns (24) and (25). These paradoxical results obviously require further discussion but are outwith the scope of the present paper.

## 8. CONCLUSIONS

In this paper the problem of the bending of curved, thin-walled tubes in the region of finite elastic deformations has been treated. A numerical analysis has been presented for the Brazier buckling of circular cross section tubes under an in-plane closing moment. As far as the author is aware, detailed load-deflection diagrams for this problem have not appeared previously in the literature, apart from the simple, energy based analysis due to Kostovetskii, which has been

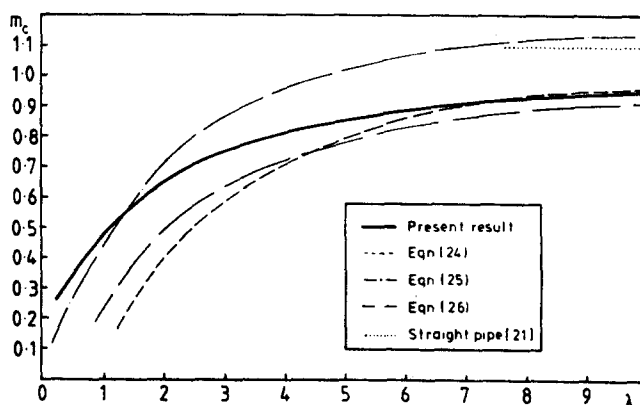

Fig. 5. Critical moment,  $m_c \nu \lambda$ .

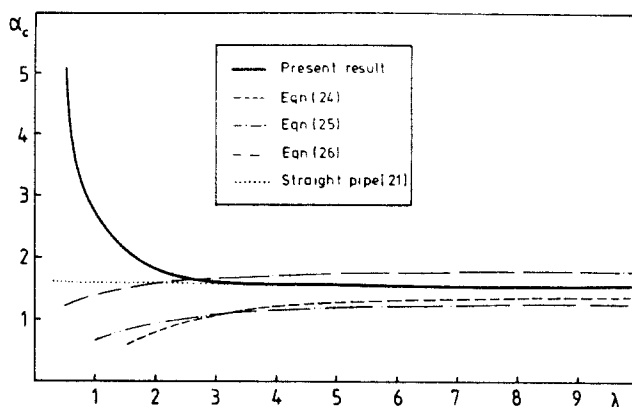

Fig. 6. Critical curvature,  $\alpha_c \lambda$ .

repeated here for comparison purposes. The range of parameters considered is largely outwith those encountered in normal design applications of curved pipes; nevertheless they should give some assistance in further studies and at least demonstrate that the phenomenon does exist. An investigation of the buckling of curved pipes is of considerable importance, but it is apparent that the simple pure bending model has its limitations and further work would probably concentrate on more complex finite element models. However, of more immediate importance, would be the inclusion of plastic strains and the effects of shape imperfections. While the former has been examined by Sobel and Newman[9], using the MARC finite element code and essentially a pure bending model, only second order effects were considered. If a second order theory is assumed here, as in Ref. [11], then the above critical behaviour does not appear; thus it would be of interest to repeat their analysis using the finite displacement model developed herein. A simple first order approximation to the latter has been described elsewhere by the writer[22], but based on the present results the problem deserves further study.

*Acknowledgements*—The author is grateful for being sent a copy of the manuscript of Ref [23] which allowed an error to be corrected at the referring stage. The author would also like to acknowledge financial assistance from the Science Research Council of Great Britain through an Advanced Research Fellowship.

#### REFERENCES

1. J. Spence, Creep of pipe bends. Doctoral dissertation, University of Strathclyde (1971).
2. G. E. Findlay, A study of smooth pipe bends under in-plane bending with reference to end-constraints. Doctoral dissertation, London (1972).
3. E. Reissner, On the bending of curved thin-walled tubes. *Proc. National Acad. Sci. (U.S.)* **35**, 204–208 (1949).
4. M. Tueda, Mathematical theories of the Bourdon pressure tubes and the bending of curved pipes. *Memoirs of the College of Engineering Kyoto University* **8**, 102–115, (1934) and **9**, 132–152, (1936).
5. E. Reissner and F. Y. M. Wan, Rotationally symmetric stress and strain in shells of revolution. *Studies in Applied Mathematics* **48**, 1–17 (1969).
6. S. H. Crandall and N. C. Dahl, The influence of pressure on the bending of curved tubes. *Proc. 9th Int. Congress on Applied Mechanics*. Brussels (1956).
7. E. Reissner, On finite bending of pressurised tubes. *Transactions ASME J. Appl. Mech.* **81**, 386–392 (1959).
8. D. L. Kostovetskii, Bending of thin-walled curved pipes in the regions of large elastic deformations *News of the Scientific Academy of the U.S.S.R. Mechanics and Machine Production* No. 3, pp. 49–54 (1960).
9. L. H. Sobel and S. Z. Newman, Instability of elbows in the plastic range. *Proc. 4th Int. Conf. Structural Mech. in Reactor Technology*. San Francisco (1977).
10. A. Robert and C. Du Foret, Influence de la pression sur la flexibilité et les contraintes dans les tuyaux centres circulairement et soumis a un moment de flexion plane ou transversale. *Bull. L'Assoc. Technique Maritime et Aero* No. 75, pp. 279–290 (1975).
11. J. T. Boyle and J. Spence, The nonlinear analysis of pressurised curved pipes. *3rd Int. Conf. on Pressure Vessel Technology*. Tokyo (1977).
12. J. Spence and J. T. Boyle, The influence of shape imperfections on stresses in piping components. *Paper C14/79 Proc. Conf. Significance of Deviations from Design Shapes*. Institute Mechanical Engineers, London (1979).
13. J. J. Stoker, *Differential Geometry*. Wiley, New York (1969).
14. W. T. Koiter and J. G. Simmonds, Foundations of shell theory. *Proc. 13th Int. Congress on Theoretical and Applied Mechanics* (Edited by E. Becker and A. K. Mikhailov, Springer-Verlag, Berlin (1973)).
15. E. Reissner, On the theory of thin elastic shells. *Contributions to Applied Mechanics. The H. Reissner Anniversary Volume*. Edwards Publishing Co. Ann Arbor (1949).
16. E. Reissner, On finite symmetrical deflections of thin shells of revolution. *Transactions ASME J. Appl. Mech.* **36**, 267–270, (1969) and **39**, 1137–1138 (1972).

17. J. G. Simmonds and D. A. Dannielsen, nonlinear shell theory with a finite rotation vector. *Proc. Koninkl Ned Akad Wetenschap* 73 (B), 460-478 (1973).
18. E. Reissner, Linear and nonlinear theories of shells. *Proc. Symp. on Thin Shell Structures: Theory, Experiment and Design Pasadena 1972* (Edited by Y. C. Fung) Prentice-Hall, New York (1974).
19. A. Kainins, Stress analysis of curved tubes. *Paper 1-19 Proc. 1st Int. Conf. on Pressure Vessel Technology*. Delft (1969).
20. L. G. Brazier, On the flexure of thin cylindrical shells and other 'thin' sections. *Proc. Royal Society Series A*, 116, 104-114 (1927).
21. J. Spence and L. H. Toh, Collapse of thin orthotropic elliptical cylindrical shells under combined bending and pressure loads. *Trans ASME J. Appl. Mech.* 46, 363-371 (1979).
22. J. T. Boyle and J. Spence, A simple analysis for oval, pressure pipe bends under external bending. *Proc. 4th Int. Conf. on Pressure Vessel Technology*, London (1980).
23. E. Reissner, On finite pure bending of curved tubes *Int. Journal Solids Structures* (To be published).
24. E. Chwalla, Reine Biegung Schlanker, dünnwandiger Rohre mit gerader Achse. *Zeit für Angewandte Math und Mechanik* 13, (1933).

## APPENDIX: KOSTOVETSKII'S ANALYSIS

Kostovetskii obtained the following coupled equations

$$m = \frac{1}{1-\nu^2}(aq_1 + \mu q_2)$$

$$\alpha = \mu \left( -\frac{q_4}{q_3} + \sqrt{\left(\frac{q_4^2}{q_3^2} - \frac{1}{q_3} \left( q_5 + \frac{(1-\nu^2)}{\pi\mu^2} B_2 \right) \right)} \right)$$

where

$$q_1 = 1 - \frac{3}{2}\delta - \frac{1}{2}\delta^2 + \frac{45}{64}\delta^3 + \frac{243}{512}\delta^4$$

$$q_2 = -\frac{3}{4}\delta + \frac{1}{16}\delta^2 + \frac{45}{64}\delta^3 + \frac{243}{512}\delta^4$$

$$q_3 = -\frac{3}{2} - \delta + \frac{135}{64}\delta^2 + \frac{243}{128}\delta^3$$

$$q_4 = -\frac{3}{4} + \frac{1}{8}\delta + \frac{135}{64}\delta^2 + \frac{243}{128}\delta^3$$

$$q_5 = \frac{5}{4}\delta + \frac{135}{64}\delta^2 + \frac{243}{128}\delta^3$$

$$B_2 = \frac{d}{d\delta} B_2 \quad B_2 = \int_0^{2\pi} \frac{\Phi_1(\phi)}{\Phi_2(\phi)} d\phi$$

$$\Phi_1 = \left( 1 + \frac{81}{256}\delta^4 + \left( 3\delta - \frac{27}{16}\delta^3 \right) \cos 2\phi + \left( 9\delta^2 - \frac{729}{128}\delta^4 \right) \cos 4\phi \right. \\ \left. + \frac{81}{8}\delta^3 \sin^2 \phi \sin 4\phi + \frac{27}{16}\delta^3 \cos 2\phi \cos 4\phi + \frac{81}{8}\delta^4 \sin^2 4\phi + \frac{1377}{256}\delta^4 \cos 4\phi \right)^2$$

$$\Phi_2 = \left( 1 + \frac{81}{256}\delta^4 + \frac{81}{16}\delta^4 \sin^2 4\phi + \frac{81}{256}\delta^4 \cos^2 4\phi - \frac{81}{128}\delta^4 \cos 4\phi \right. \\ \left. + \frac{27}{4}\delta^3 \sin 2\phi \sin 4\phi \right)^3.$$

A relationship between  $m$  and  $\alpha$  can be found on eliminating  $\delta$  from the above. Of necessity this must be done numerically.

(For the interested reader a listing of a simple BASIC computer program which solves these equations is available on request from the author).